

OUTER DIMENSIONS in mm:-

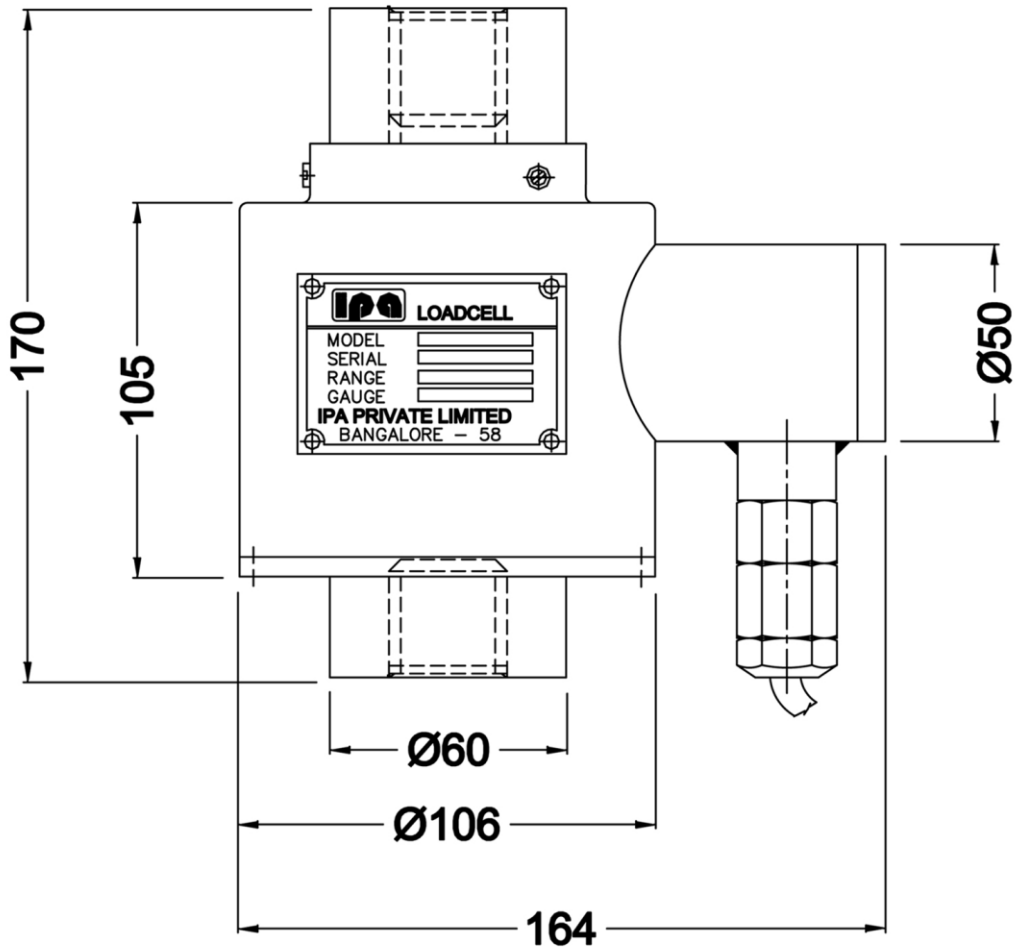

DIMENSION DETAILS:-

CAPACITY (TON)	MODEL NO
2	TH023H0
3	TH033H0
5	TH053H0
10	TH014H0

EXPLODED VIEW

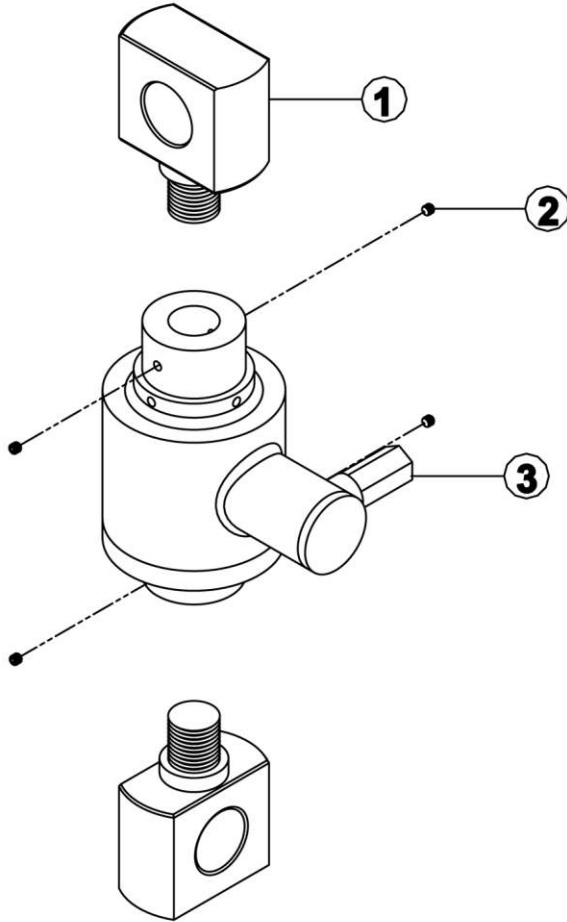

PART LIST

NO	DESCRIPTION	QTY./ ASSY
1	SHACKLE	2
2	GRUB SCREW	4
3	LOAD CELL-TH	1

ASSEMBLED VIEW

